

BRUSSO®

Incorporated

PRECISION HARDWARE

LID STAY INSTALLATION INSTRUCTIONS

Drill a hole (A. Diameter) in box lid with its center (B. Distance from center of box hinge pin). Cut mortise into side of box (C. Length) (D. Width) and (E. Depth) with its end (F. Distance) from center of the box hinge pin. Glue or epoxy hanger into drilled hole to depth of its shoulder. Once installed, hanger must drop into hole in lid support body without binding.

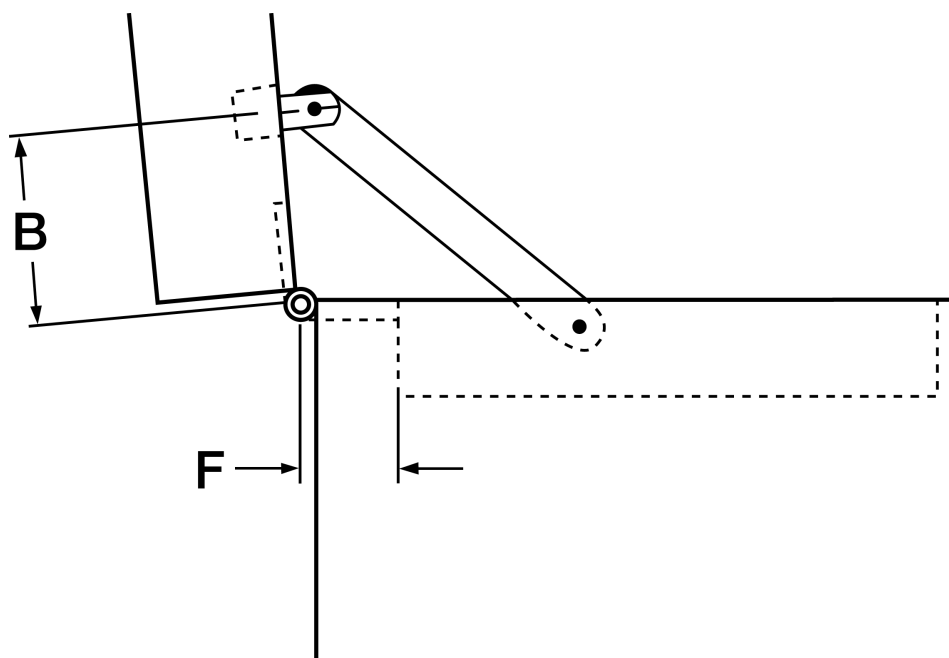

JB-250 JB-280

A. Diameter	1/4"	7/16"
B. Distance	1"	1 1/2"
C. Length	2 7/8"	4 5/16"
D. Width	1/4"	3/8"
E. Depth	1/2"	3/4"
F. Distance	1/2"	3/4"